



Model Number

OBE500-R3F-SE2-Y263493

Thru-beam sensor (pair)
with 2 m fixed cable

Features

- Very flat design for direct mounting without mounting bracket
- TEACH-IN
- Detection of partially transparent objects by teach-in
- Very bright, highly visible light spot

Dimensions

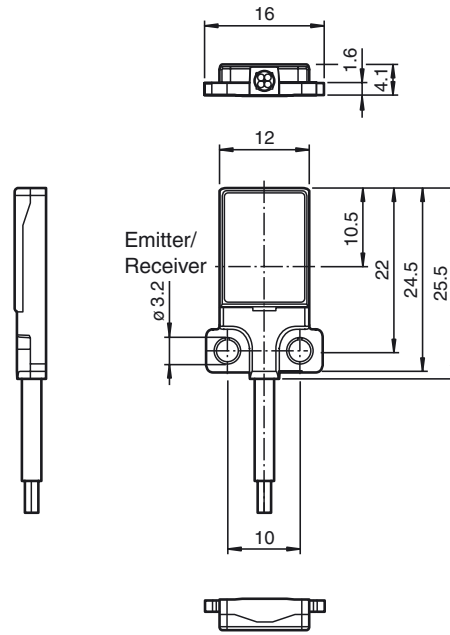

Electrical connection

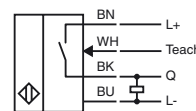
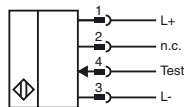

Technical data**System components**

Emitter	OBE500-R3F-S
Receiver	OBE500-R3F-E2-Y814218

General specifications

Effective detection range 0 ... 500 mm

Threshold detection range 700 mm

Light source LED

Light type modulated visible red light , 630 nm

LED risk group labelling exempt group

Angle deviation approx. 2 °

Object size typ. starts from 1.5 mm

Diameter of the light spot approx. 60 mm at a distance of 500 mm

Angle of divergence approx. 5 °

Optical face frontal

Ambient light limit EN 60947-5-2 : 25000 Lux

Functional safety related parameters

MTTF_d 806 a

Mission Time (T_M) 20 a

Diagnostic Coverage (DC) 0 %

Indicators/operating means

Operation indicator LED green, statically lit Power on , short-circuit : LED green flashing (approx. 4 Hz)

Function indicator Receiver: LED yellow, lights up when light beam is free, flashes when falling short of the stability control ; OFF when light beam is interrupted

Electrical specifications

Operating voltage U_B 10 ... 30 V DC

No-load supply current I₀ Emitter: ≤ 11 mA
Receiver: ≤ 8 mA

Protection class III

Input

Test input Test of switching function at 0 V

Switching threshold Teach-In input

Output

Switching type NO contact / dark on

Signal output 1 PNP output, short-circuit protected, reverse polarity protected, open collector

Switching voltage max. 30 V DC

Switching current max. 50 mA , resistive load

Voltage drop U_d ≤ 1.5 V DC

Switching frequency f approx. 1 kHz

Response time 500 μs

Directive conformity

Electromagnetic compatibility

Directive 2014/30/EU EN 60947-5-2:2007 EN 60947-5-2/A1:2012

Standard conformity

Standards EN 60947-5-2:2007 EN 60947-5-2/A1:2012 EN 62471:2008 UL 60947-5-2: 2014

Ambient conditions

Ambient temperature -25 ... 60 °C (-13 ... 140 °F)

Storage temperature -20 ... 70 °C (-4 ... 158 °F)

Mechanical specifications

Degree of protection IP67

Connection 2 m fixed cable

Material

Housing PC (Polycarbonate) and Stainless steel

Optical face PMMA

Cable PUR

Mass approx. 20 g Per sensor

Tightening torque, fastening screws 1 Nm

Cable length 2 m

Approvals and certificates

UL approval E87056 , cULus Recognized, Class 2 Power Source

CCC approval CCC approval / marking not required for products rated ≤36 V

Other suitable accessories can be found at

Curves/Diagrams

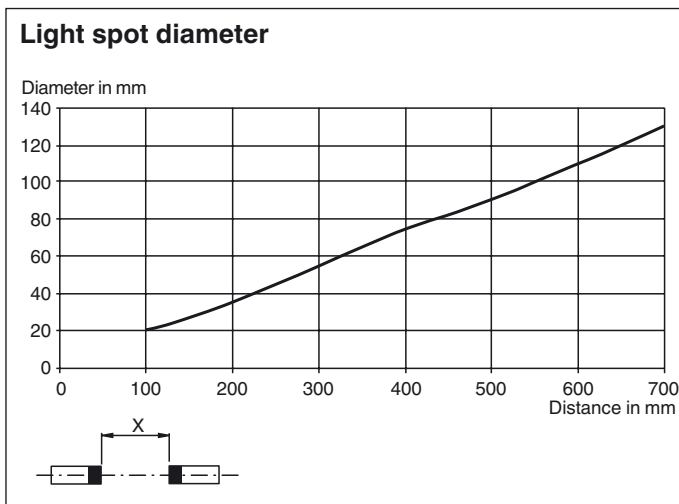
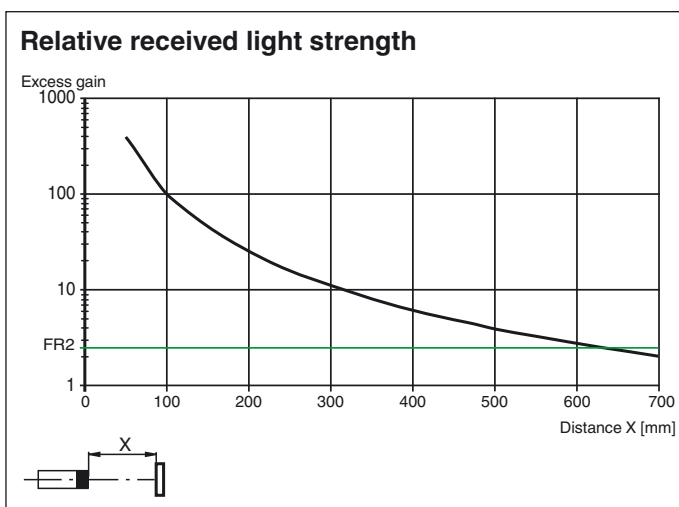
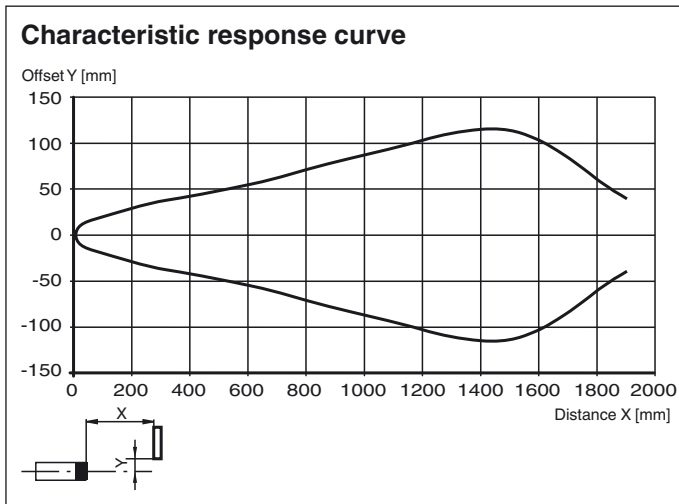

Teach-In Methods

The thru-beam sensor enables the switching points to be taught in for optimum adaptation to specific applications. This eliminates the need for additional components such as apertures.

The sensitivity of the thru-beam sensor can be adjusted using three Teach-in methods:

Position Teach

When using this Teach-in method, the following settings are made on the thru-beam sensor:

- The gain is set to an optimum value
- The signal threshold is set to a minimum

Release date: 2017-02-16 14:40 Date of issue: 2017-02-22 263493_eng.xml

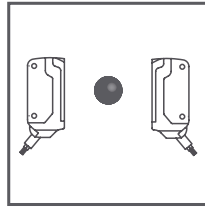
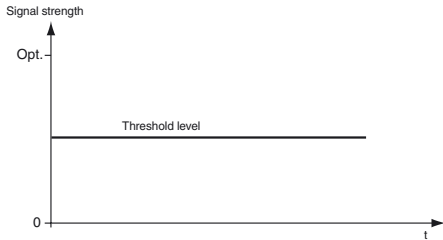

Recommended application:

This method enables minuscule particles in the beam path to be detected, and provides exceptional positioning accuracy. Make sure that there are no objects in the beam path and that the sensor is connected to the power supply.

1. Connect the white cable on the receiver (WH/IN) to the blue cable (BU/0 V) on the receiver. The green and yellow LED indicators flash simultaneously at 2.5 Hz
2. Disconnect the white cable on the receiver (WH/IN) from the blue cable (BU/0 V) on the receiver. The green and yellow LED indicators flash alternately at 2.5 Hz
3. The end of the Teach-in process is indicated when the green LED indicator lights up solid and yellow LED blinks.

Two-Point Teach-In

When using this Teach-in method, the following settings are made on the thru-beam sensor:

- The gain is set to an optimum value
- The signal threshold is set in the center between the two taught signal values

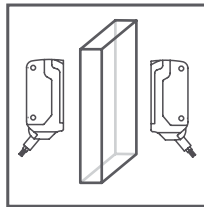
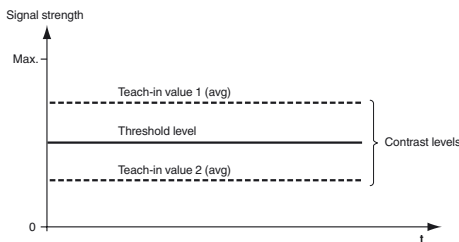

1. Make sure that there are no objects in the beam path and that the sensor is connected to the power supply.
2. Connect the white cable on the receiver (WH/IN) to the blue cable (BU/0 V) on the receiver. The green and yellow LED indicators flash simultaneously at 2.5 Hz
3. Position the object in the beam path.
4. Disconnect the white cable on the receiver (WH/IN) from the blue cable (BU/0 V) on the receiver. The green and yellow LED indicators flash alternately at 2.5 Hz
5. The end of the Teach-in process is indicated when the green LED indicator lights up solid.

Maximum Teach-In

When using this Teach-in method, the following settings are made on the thru-beam sensor:

- The gain is set to a maximum
- The signal threshold is set to a minimum

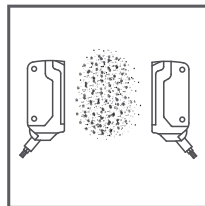
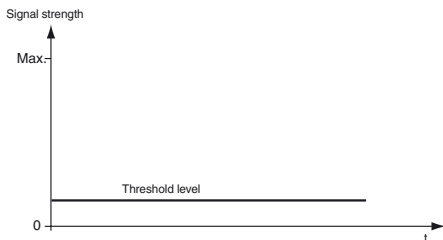

Recommended application:

Enables an object to be detected with a high excess gain. This can be useful if there is severe environmental contamination or to achieve long operating times.

Make sure that there are no objects in the beam path and that the sensor is connected to the power supply.

6. Cover the receiver or transmitter.
7. Connect the white cable on the receiver (WH/IN) to the blue cable (BU/0 V) on the receiver. The green and yellow LED indicators flash simultaneously at 2.5 Hz
8. Disconnect the white cable on the receiver (WH/IN) from the blue cable (BU/0 V) on the receiver. The green and yellow LED indicators flash alternately at 2.5 Hz
9. The end of the Teach-in process is indicated when the green LED indicator lights up solid.